

OCR

Oxford Cambridge and RSA

Wednesday 6 November 2024 – Morning

GCSE (9–1) Mathematics

J560/04 Paper 4 (Higher Tier)

Time allowed: 1 hour 30 minutes

You must have:

- the Formulae Sheet for Higher Tier (inside this document)

You can use:

- a scientific or graphical calculator
- geometrical instruments
- tracing paper



Please write clearly in black ink. **Do not write in the barcodes.**

Centre number

--	--	--	--	--	--

Candidate number

--	--	--	--

First name(s)

Last name

INSTRUCTIONS

- Use black ink. You can use an HB pencil, but only for graphs and diagrams.
- Write your answer to each question in the space provided. If you need extra space use the lined page at the end of this booklet. The question numbers must be clearly shown.
- Answer **all** the questions.
- Where appropriate, your answer should be supported with working. Marks might be given for using a correct method, even if your answer is wrong.
- Use the π button on your calculator or take π to be 3.142 unless the question says something different.

INFORMATION

- The total mark for this paper is **100**.
- The marks for each question are shown in brackets [].
- This document has **20** pages.

ADVICE

- Read each question carefully before you start your answer.

2

1 Factorise fully.

(a) $6x^2 + 9x$

(a) [2]

(b) $x^2 + 8x + 15$

(b) [2]

2 You may use these kinematics formulae to answer these questions.

$$v = u + at$$

$$v^2 = u^2 + 2as$$

A moving particle accelerates at 2 m/s^2 for 8 seconds.
The particle's final velocity after the 8 seconds is 21 m/s.

(a) Show that the velocity of the particle at the start of the 8 seconds is 5 m/s. [2]

(b) Work out the distance travelled by the particle during the 8 seconds.

(b) m [3]

3

3 (a) N is a number such that:

- $N = 3 \times 5 \times k$, where k is a prime number
- N is greater than 400.

Find the smallest possible value of N .

(a) $N = \dots\dots\dots$ [3]

(b) a and b are different prime numbers.

Explain why $a \times b$ is not a prime number.

.....
..... [1]

4

- 4 Each week the manager of a petrol station records the average daily sales, in litres, and the average price, in pounds, of a litre of petrol for that week.

The table shows their results for ten weeks.

Week	1	2	3	4	5	6	7	8	9	10
Price per litre (£)	1.42	1.45	1.47	1.50	1.54	1.60	1.57	1.52	1.61	1.46
Litres sold per day	740	725	620	705	685	660	675	695	655	715

The results for the first nine weeks are plotted on the scatter diagram.

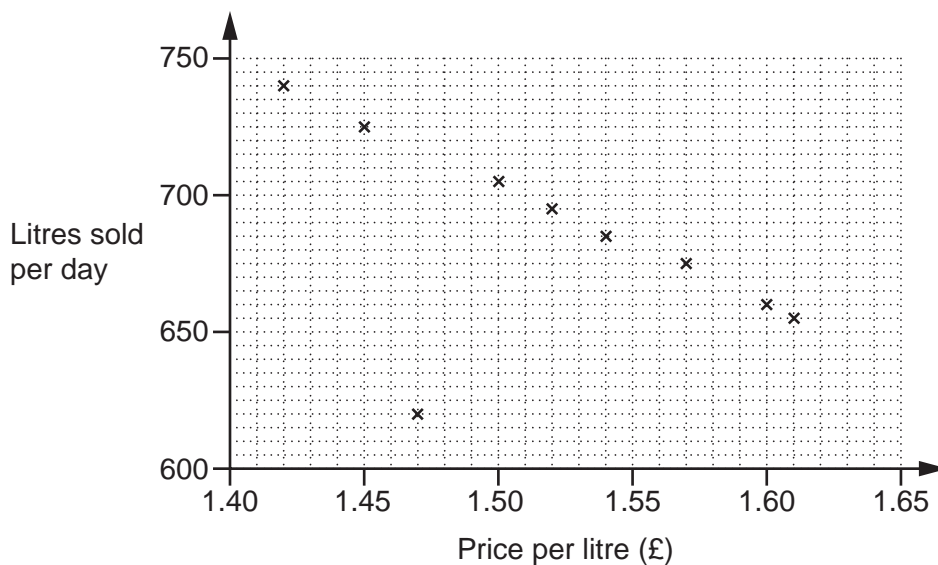

- (a) Plot the result for week 10. [1]
- (b) Describe the type of correlation shown in the scatter diagram. [1]
- (b)
- (c) In one week, there was a delay with petrol deliveries. [1]
- Circle the most likely point on the scatter diagram for that week. [1]
- (d) (i) On the scatter diagram, draw a line of best fit. [1]
- (ii) Use the line of best fit to estimate the average daily sales when the price per litre of petrol is £1.48. [1]
- (d)(ii) litres

5

(e) The manager says,

As the sales go down, the total amount of money we take stays roughly the same.

Find evidence to support this statement.

.....
..... [3]

5 A person invests £8000 at a rate of 5% per year compound interest.

Calculate the total amount of **interest** earned after 3 years.

£ [3]

6

- 6 The diagram shows an equilateral triangular prism.
 Each side of the equilateral triangle is 6 cm and the length of the prism is 7 cm.

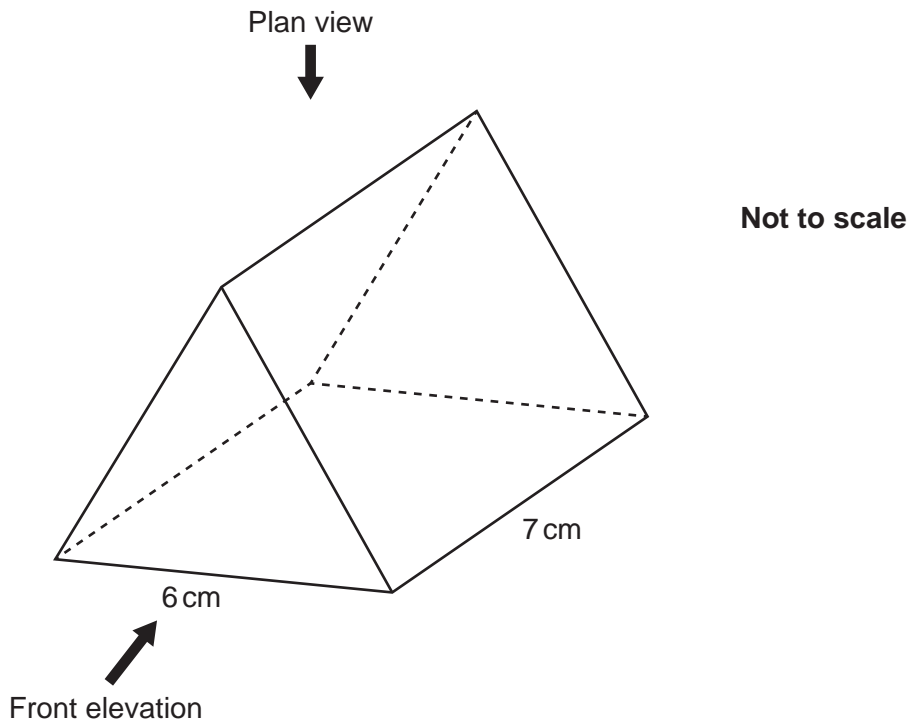

- (a) Draw an accurate plan view of the prism on the one-centimetre square grid below.

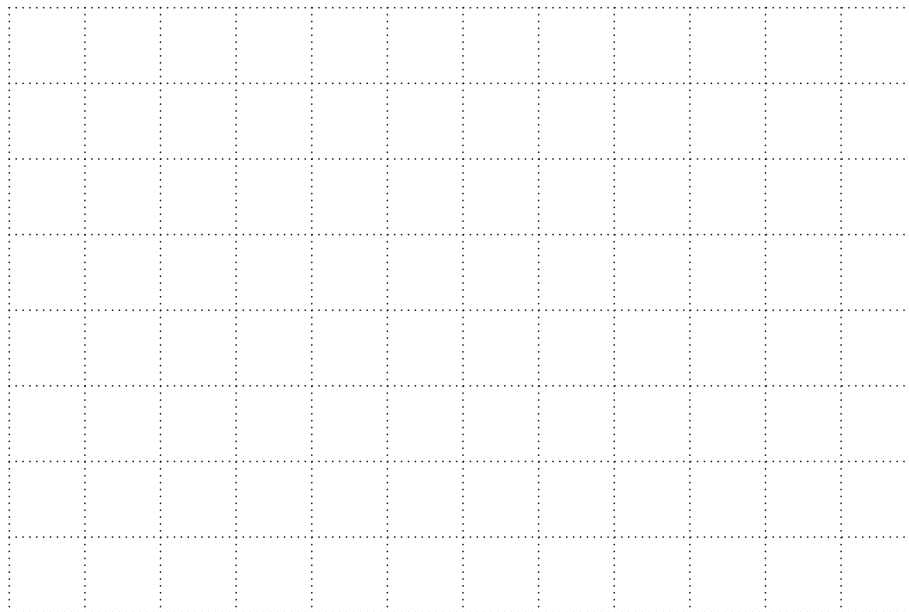

[3]

7

(b) Draw an accurate front elevation of the prism on the one-centimetre isometric grid below.



[2]

7 A rock has a mass of 36 920 g and a volume of 14 200 cm³.

Work out the density of the rock.

Give the units of your answer.

..... [3]

8

- 8 There is a total of 354 balls in a bag.
There are white balls, red balls and green balls only.

The ratio of white balls to red balls is 3 : 4.

The ratio of red balls to green balls is 5 : 6.

Work out the number of green balls in the bag.

..... [4]

9

- 9 A cylinder has a radius of 8.4 cm.
The ratio of the radius of the cylinder to the height of the cylinder is 2:5.

Find the volume of the cylinder.

..... cm³ [4]

10

10 Here is a table of values for $y = x^2 - x - 8$.

x	-4	-3	-2	-1	0	1	2	3	4
y	12	4	-2	-6	-8	-8	-6	-2	4

(a) Draw the graph of $y = x^2 - x - 8$ for $-4 \leq x \leq 4$.

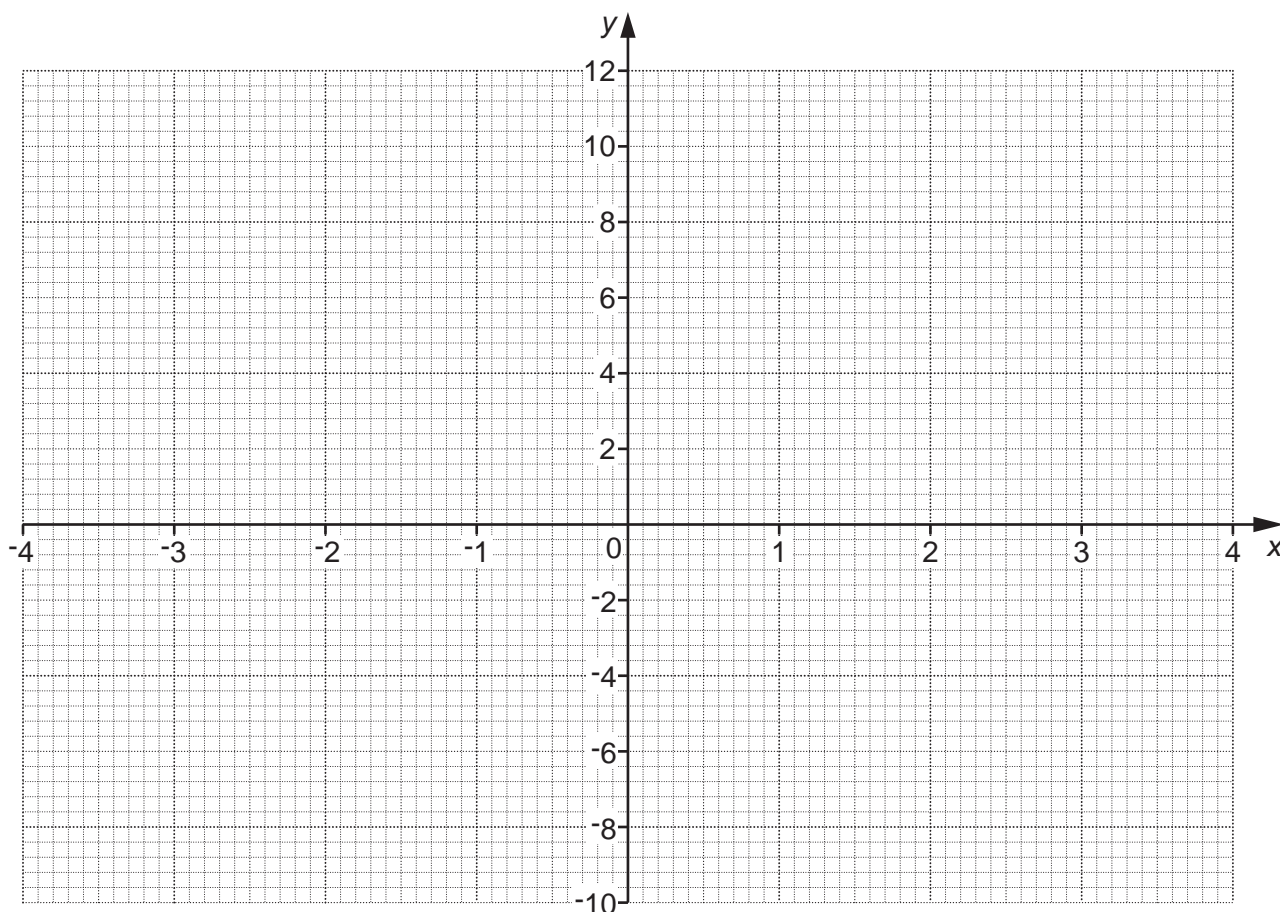

[3]

(b) Write down the equation of the line of symmetry of the graph.

(b) [1]

(c) Use the graph to solve the equation $x^2 - x - 8 = 0$.
Give your answers to 1 decimal place.

(c) $x =$ or $x =$ [2]

11

- 11 Triangles ABC and PQR are mathematically similar.
Angle ACB = Angle PRQ.
Angle ABC = Angle PQR.

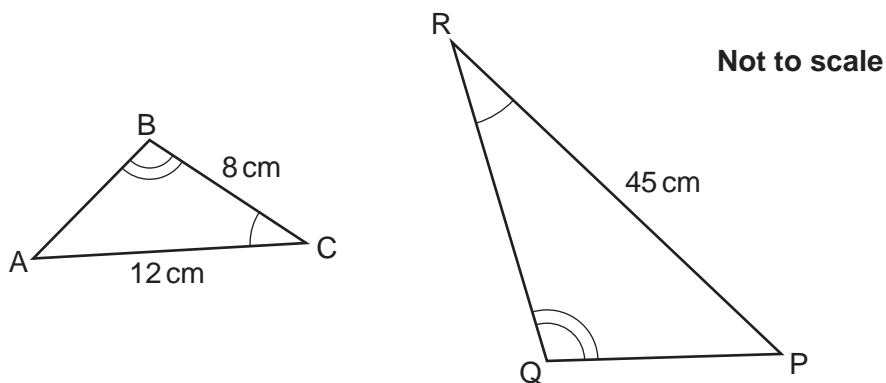

The perimeter of triangle PQR is 99 cm.

Find the length of PQ.

PQ = cm [4]

12

- 12 y is directly proportional to the square of t .
 $y = 14$ when $t = 2$.

t is directly proportional to x .
 $t = 12$ when $x = 3$.

Find a formula for y in terms of x .
Give your answer in its simplest form.
You must show your working.

$y = \dots\dots\dots$ [6]

- 13 A water company is laying pipes to cover a distance of 37 metres, correct to the nearest metre. Each pipe has a length of 2.3 metres, correct to 1 decimal place. Assume the pipes are laid end to end with no gaps or overlaps.

Work out the minimum number of pipes the water company needs to be sure of covering that distance.
You must show your working.

$\dots\dots\dots$ [4]

14 The histogram summarises the heights, h cm, of some plants in a garden centre.

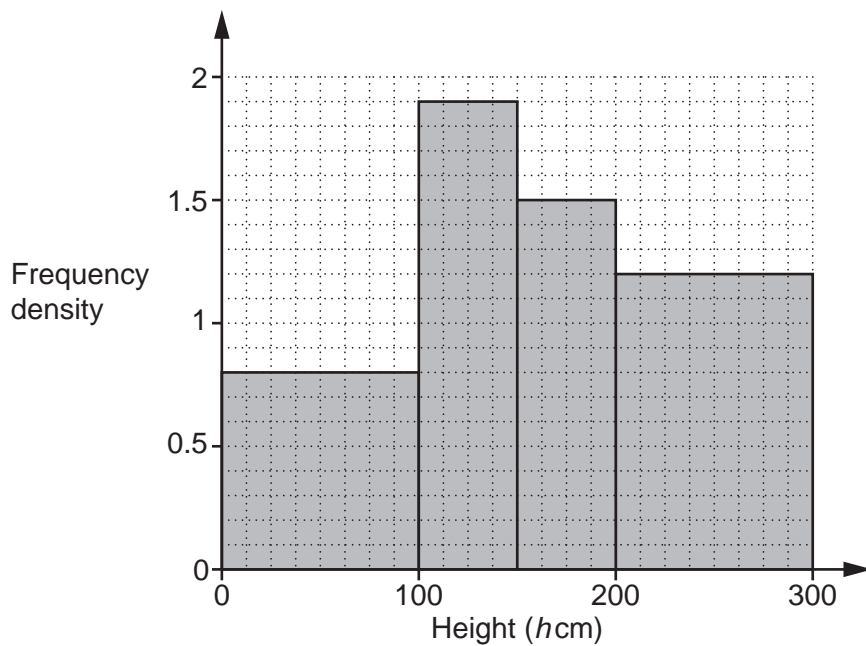

(a) Show that there are 80 plants with a height in the interval $0 < h \leq 100$. [1]

(b) The value, in pounds, of each plant depends on the plant's height. The table below shows this information.

Height (h cm)	Value (£)
$0 < h \leq 100$	2.50
$100 < h \leq 150$	3.40
$150 < h \leq 200$	5.00
$200 < h \leq 300$	6.30

Use this information to find the **total** value of the plants represented in the histogram.

(b) £ [4]

14

- 15 In a survey, some students were asked whether they had travelled to school by bus (B) or by car (C) in the last week.

The Venn diagram shows some of the results.

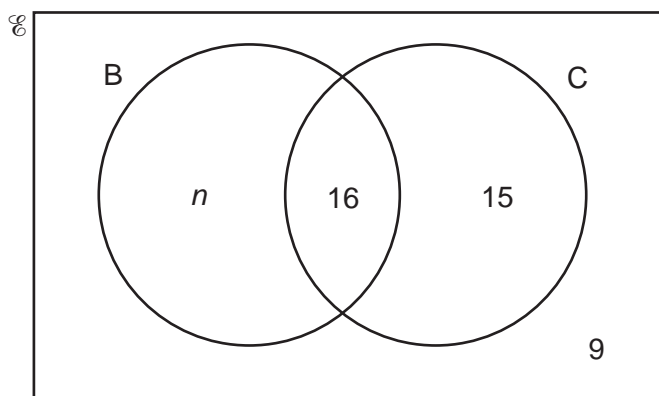

- (a) One of the students is chosen at random.
The probability that, in the last week, this student had travelled to school by bus and by car is $\frac{1}{4}$.

Find the value of n .

(a) $n = \dots\dots\dots$ [3]

- (b) One of the students is chosen at random.

Find the probability that, in the last week, this student had travelled to school by car given that they had also travelled to school by bus.

(b) $\dots\dots\dots$ [2]

15

16 AC is a diagonal of the quadrilateral ABCD.

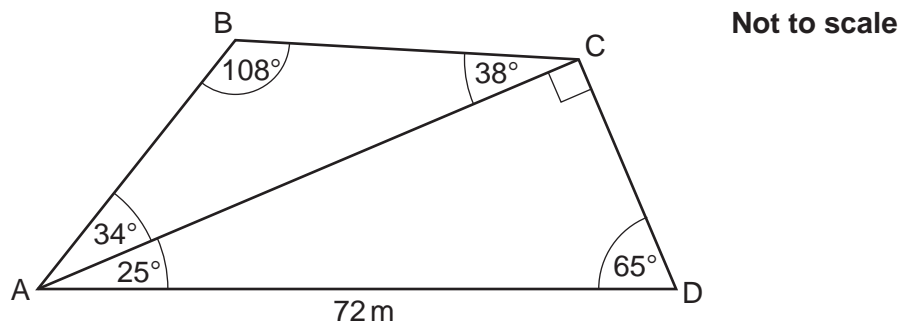

$AD = 72 \text{ m}$.

Angle $ABC = 108^\circ$, angle $BCA = 38^\circ$ and angle $BAC = 34^\circ$.

Angle $ACD = 90^\circ$, angle $CDA = 65^\circ$ and angle $CAD = 25^\circ$.

Find the area of ABCD.

You must show your working.

..... m^2 [6]

16

- 17 An app's passcode consists of three digits. Each of the digits is a number from 0 to 9. A digit can be used more than once.

Find the fraction of the possible passcodes that contain at least one 5.

..... [4]

18 Some sequences are defined using this term-to-term rule.

$$u_{n+1} = 5u_n - 8.$$

(a) If $u_3 = 22$, show that $u_4 = 102$.

[1]

(b) If $u_3 = 22$, work out u_2 .

(b) [3]

(c) If $u_1 = 2$, write down the value of u_{50} .
Give a reason for your answer.

$u_{50} =$ because

..... [2]

18

- 19 Two ornaments, A and B, are mathematically similar.
The table shows information about the two ornaments.

	Ornament A	Ornament B
Height (m)	h	12
Surface area (m^2)	216	A
Volume (m^3)	240	3750

Find the value of h and the value of A .
You must show your working.

$$h = \dots\dots\dots$$

$$A = \dots\dots\dots [6]$$

20 (a) Show that the equation $x^3 - 3x - 4 = 0$ has a solution between $x = 2$ and $x = 3$. [3]

(b) Use $x = 2.5$ to find a smaller interval for the solution to $x^3 - 3x - 4 = 0$.
You must show your working.

(b) [2]

(c) Find this solution correct to 1 decimal place.
You must show your working.

(c) $x =$ [3]

END OF QUESTION PAPER

EXTRA ANSWER SPACE

If you need extra space use this lined page. You must write the question numbers clearly in the margin.

Lined area for writing answers, consisting of a vertical margin line on the left and horizontal dotted lines for writing.



Copyright Information

OCR is committed to seeking permission to reproduce all third-party content that it uses in its assessment materials. OCR has attempted to identify and contact all copyright holders whose work is used in this paper. To avoid the issue of disclosure of answer-related information to candidates, all copyright acknowledgements are reproduced in the OCR Copyright Acknowledgements Booklet. This is produced for each series of examinations and is freely available to download from our public website (www.ocr.org.uk) after the live examination series.

If OCR has unwittingly failed to correctly acknowledge or clear any third-party content in this assessment material, OCR will be happy to correct its mistake at the earliest possible opportunity.

For queries or further information please contact The OCR Copyright Team, The Triangle Building, Shaftesbury Road, Cambridge CB2 8EA.

OCR is part of Cambridge University Press & Assessment, which is itself a department of the University of Cambridge.